

HDU
Hard Disk Unit
MANUAL

20.03.1987 Software Version 1 Rev. 4.5.

Congratulations !

As owner of the HDU you have a Music Instrument in your hands with a unique conception of hard and software which reaches really revolutionary areas of music and sound modulation.

Although the HDU already sets standards for future developments its abilities will be able to be extended through software options which PPG will from time to time offer.

You will be familiar with some aspects of handling the HDU and with some not.

That is perfectly natural when new developments are made.

We have taken a lot of care and thought when considering the optimum solutions of handling the HDU and are convinced that we are on the right way.

However, we shall always be very grateful for suggestions.

No matter whether you use the HDU in a MIDI studio, or when putting sound to film, or on the stage or in a professional studio, you will find that the areas of manipulation are so big that we would express our sincere wish of your working through the whole manual in order to understand the instrument completely.

A general survey commences every Chapter and points out special features to be watched for.

In order to avoid the danger of loosing important data, and therefore also time, we would like to emphasize the importance of reading the hints and explanations at the beginning.

Have lots of fun with the HDU!

Table of Contents

Section A:	Page
Important hints when working with the HDU.....	1
Working with the Commander.....	3
 Section B:	
Page 1 Playback (General Survey).....	1
1) Playback.....	1
2) Creating an M-File (Multitrack).....	3
2.1) Setting Start and End Cue Points.....	3
2.2) Start Time Update.....	4
3) Saving a Multitrack.....	5
4) Playing Multitracks with the Commander.....	5
5) Erasing a Multitrack or Event.....	5
6) MIDI in Page 1 Playback.....	6
7) Automatic finder for M-files	6
 Section C:	
Page 1 Recording	
1) General Survey	1
2) Recording the first Track.....	2
3) Recording additional Tracks.....	3
4) Page 1 Recording and MIDI.....	5
 Section D:	
Page 4 Time and Pitch Correction	
1) General Survey.....	1
2) Working with Page 4	2
3) Time Manipulation.....	3
3.1) Using P 3	4
3.2) Using MIDI	4
3.3) Using a Predetermined Playback Time	4
4) Saving a Multitrack with Pitch and Time Manipulation.....	4
5) MIDI in Page 4	5

Section E:	Page
1) Page 2 Realtime Effects General Survey	1
2) Selecting different Effects.....	3
3) Saving Programs and Arrangements.....	3
4) Names function on Page 2.....	4
5) MIDI in Page 2.....	4
Preset-Effects and Routing programs.....	5
Page 2 Echo.....	6
Page 2 Phasing.....	7
Page 2 Flanging.....	8
Page 2 Distortion.....	8
Page 2 Filter.....	10
Page 2 Harmonizing.....	11

Section F:

Page 2 Resampling and Mixdown	
1) Playback of one Track via effect.....	1
2) Recording an external source via effect.....	3
3) Playback and recording of one Track via effect (Resampling)	4
4) Mixing of two track.....	5

Section G:

Page 3 Song Editor MIDI	
1) General Survey.....	1
2) Creating a Song.....	4
3) Manual Playback of a Song.....	5
4) Saving a Song.....	5
5) Setting Cues and playing controlled via MIDI Sequencer	6
6) Comment Line	7
Page 3 Digital Cutting	
1) General Survey.....	8
2) Example of Cutting.....	8
Page 5 Song Editor SMPTE	
1) General Survey	10
2) Creating a song	10
3) Setting Cues and playing back a song on Page 5	10

Section H:	Page
MIDI of the HDU	
1) General Survey.....	1
Selecting a MIDI channel.....	1
2) MIDI Exclusive Parameter List	2
3) MIDI exclusive Page 1.....	3
4) MIDI exclusive Page 4.....	3
5) MIDI exclusive Page 2 Echo.....	3
6) MIDI exclusive Page 2 Phasing.....	4
7) MIDI exclusive Page 2 Flanging.....	4
8) MIDI exclusive Page 2 Distortion.....	5
9) MIDI exclusive Page 2 F.I.R. Filter.....	5
10) MIDI exclusive Page 2 Pitch Transposer.....	5

Section K:

1) Saving a Backup of the Sound Recording Directory	1
Page 0.02 DIAGNOSTIC	
1) General Survey	2
2) Initializing the Hard Disk Sound Recording Directory	2
3) Tape Streamer operations ..(Version 1.5)	3
4) Identity Number of your Software	5
5) The Softkey Recorder.....	6

SECTION A

A few **important** hints when working with the HDU

First connect the remote controller (COMMANDER) to the HDU using the cable provided and connect the HDU to your audio inputs as required.

The following inputs and outputs are available:

MIDI 1 IN/OUT and Thru, four audio separate outputs, two stereo outputs, a mono output, two stereo inputs and a stereo headphone output.

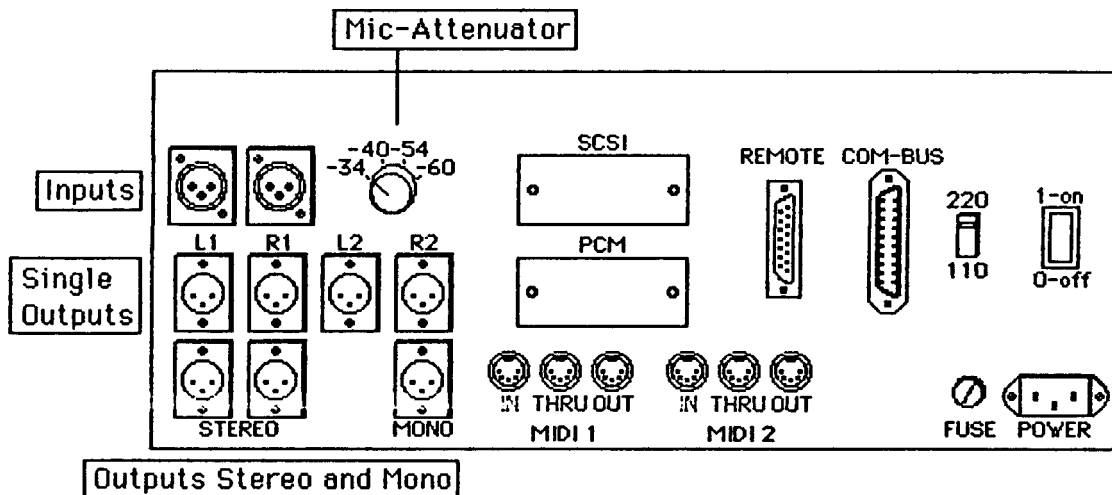

Important:

When you record with line in the Mic-Attenuator has to be switched to **-34 !**

All audio outputs and inputs are electronically balanced.

L1+L2 = left stereo channel / R1+R2 = right stereo channel

Pins: 1 = gnd, 2 = signal minus, 3 = signal plus

Switch on the HDU.

It takes about 30 seconds before the message appears:
"HDU is ready"

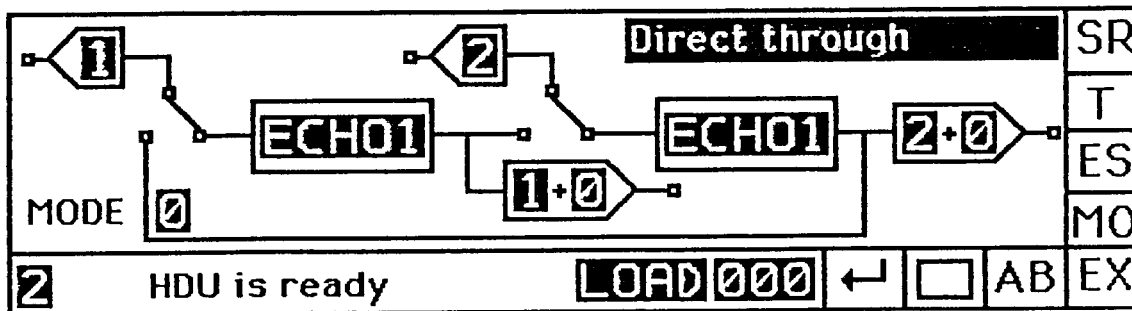

The HDU needs this time in order that the Winchester Drive achieves its working speed, and then to load 50 Preset Arrangements, all the 950 User Arrangements, the Sound Recording Directory and the 100 Softkey Recordings..

All the sounds which you have recorded and modified can be directly accessed following the above-mentioned power up procedure.

WARNING:

Your HDU should always be treated with respect and not thrown around !
Above all we would like to point out that the Winchester Drive is in a more sensitive state when powered up than when not.
Nevertheless the HDU can be transported and used on stage like all other instruments.
Please note that the HDU is a 16 bit digital audio System which has an extremely high dynamic range and can produce very high transients which can cause damage to your audio equipment.
PPG cannot take any responsibility for damages to your equipment.

WORKING WITH THE COMMANDER

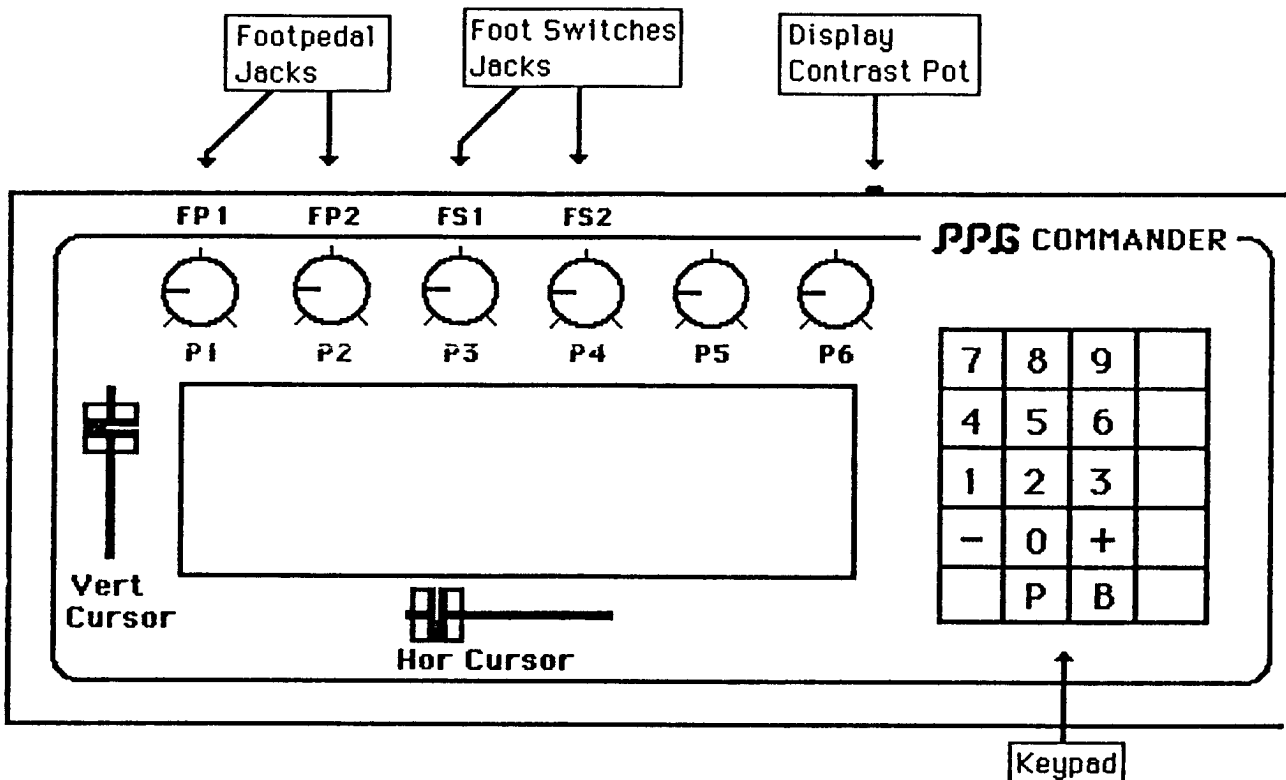

The two faders control the actual position of the cursor. The cursor blinks and displays the current input field. The six rotary pots take on various functions depending on which Page you are working. The first two Rotary pots (P1 and P2) can also be controlled by footpedals. In this case the two rotary pots have no effect.

Using a footswitch at FS1 allows a progressive switching of various Programs on different Pages.

Using a footswitch at FS2 you can start and reset recording and playback when the commentary displays: "Start = 1".

The numerical keypad has the following functions:

- 1) Entering numerical values
- 2) Choice of Roll Functions using "+" and "-"

Roll Functions are particularly important for commands which have various functions on the same field. For example when you are on the "LOAD" field you can reach "SAVE" and "DELETE" by using the "+" and "-"

keys.

The "+" and "-" keys can also be used for precisely adjusting numerical values for such things as DELAY and ECHO times.

3) The remaining keys on the keypad correspond to the right hand corner of the display.

A few keys keep the same functions on all Pages while others change.

The functions which always stay the same are:

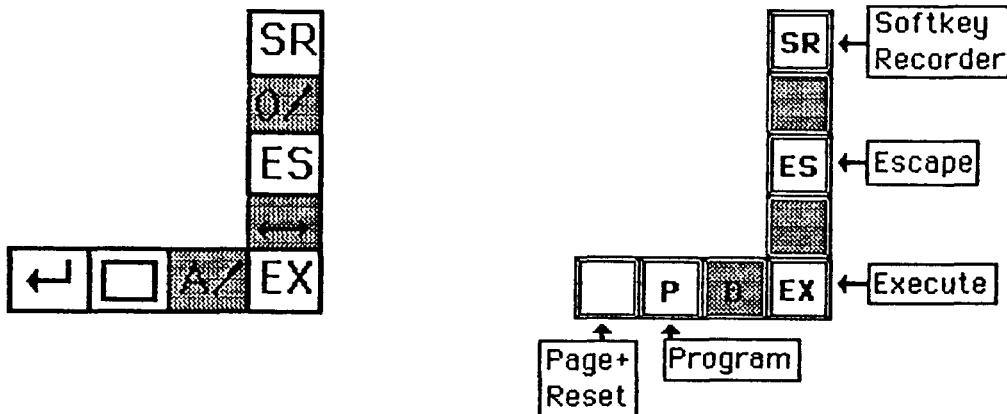

Softkey Recorder allows storing and instant recalling of chains of values made on the keypad (Refer to Section K)

Escape serves to stop playback or to escape from any function

Execute is the executive command for all complex functions.

P represents Program or Multitrack and can be used for rapid loading on all Pages

Page + Reset This key has two functions:
1) for rapid Page selection
2) as Restart when playback or recording are running.

The COMMANDER provides commentaries and assistance in the lower line of the display.

The commentaries which appear there are shown in this manual in following way:

Playb. this track ?

Commands and values entered with the keypad are represented in this manual as follows:

P

In addition this key **1** also has the function "YES"

and this key **0** also has the function "NO"

The functions "YES" and "NO" are only used in answer to questions posed by the COMMANDER.

SECTION B

PAGE 1 Playback

Enter this Page by pressing  and  and the display shows

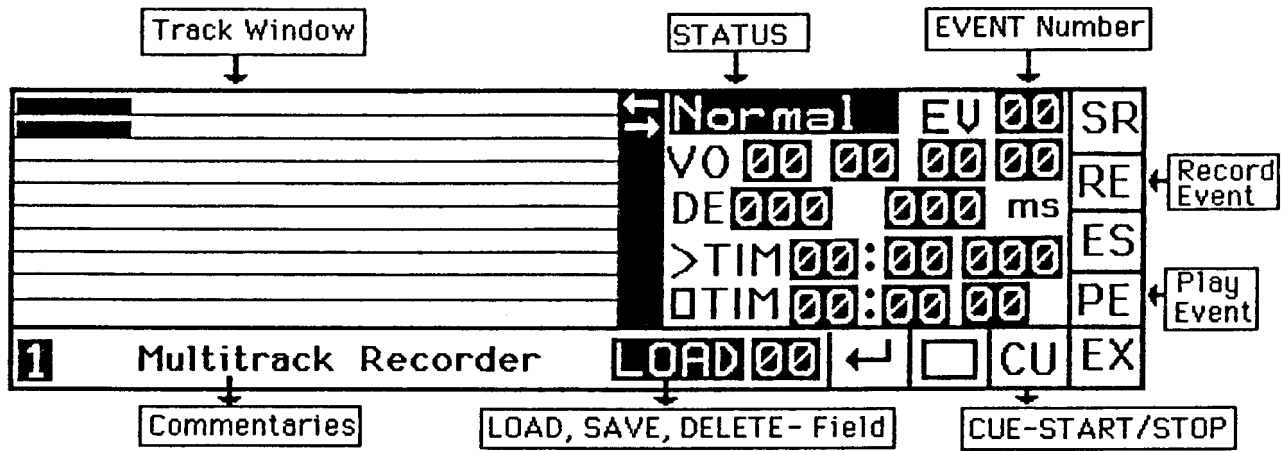

VO 00 00 00 00 → Volume Tracks 1 to 4 (P 1 to P 4)

DE 000 000 ms → Delay for Track 1 and Track 3 (P 5 and P 6)

>TIM 00:00 000 → Start Time field (min. sec. and hundredth of sec.)

◻TIM 00:00 000 → Stop Time Field (min. sec and hundredth of sec)

1) Playback

The Hard Disk comes to you with sounds from EVENT 00 and 01 already stored. Use these EVENTS for the following examples.

The following commands must be made using the COMMANDER's keypad in order to play back:

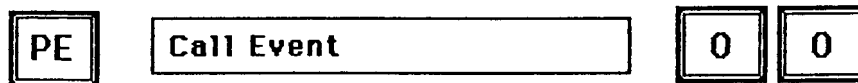

After the EVENT has been called up you will see an arrow pointing to the right which shows that this track is available for playback. In addition you can see how many tracks this EVENT contains by means of the little bars under the arrow.

Playb. this track ?

Answer the COMMANDER's question "Playb. this track?" by either entering a "1" for YES or a "0" for NO.

A maximum of four tracks can be played back simultaneously.

Example:

1

1

0

0

This means that tracks one and two will be played back and track three and four not.

When the commentary says:

Start = 1 00:00,00

you can start the playback with:



While the EVENT is being played back you can see the tracks appearing in the Track Window.

Each EVENT has a predetermined length in time and will stop automatically when this time is reached. If you wish to stop the playback manually

Press:



If you want to try out the modifying features of this Page do the following:

Start the EVENT again as described above.

While the EVENT is playing you can reset it to its starting point at any time immediately simply by pressing:



This is a particularly helpful feature which avoids having to load the EVENT every time you wish to hear it or try out different modifications.

The rotary pots P 1 to P 4 control the volume of the 4 tracks available for playback. This means that using the above example P 1 and P 2 will control the volume of the tracks playing back while P 3 and P 4 have no function.

The rotary pots P 5 and P 6 control the delay of tracks 1 and 3. This means that using this example you have the possibility of delaying track 1.

Try it out by turning rotary pot P 5. You can see how much delay you have in the display. You can adjust the delay finely by either using the "+"/"- keys or by numerically entering the delay required with the keypad after having moved the cursor to the corresponding delay field.

2) Creating a Multitrack

Now we want to describe how to create a MULTITRACK which is an easy way of storing and loading a modified EVENT.

A MULTITRACK is an EVENT which, together with a number of unique playback commands, can be called up with a single command either via MIDI (Program Change) or by using key "P" on the COMMANDER.

In addition to the modifying features mentioned above (Volume and Delay) you can also determine how many tracks will be played and set exact start and end cue points.

The start and end cue points can be varied as often as required and in no way change the recorded material.

Load the EVENT required as described above.

Now you must decide how many tracks you wish to hear.

The display shows:

Start = 1 00:00,00

Before you press

1

to start please read the following:

2.1) Setting Start and End Cue Points

It is possible to either set the start and end cue points in realtime, that is while the playback is running, or to set the cues numerically using the cursor and keypad.

Start the playback by pressing

1

Move the cursor to the start time field. **>TIM 00:00 000**

While the playback is running select a new point where you would like the

playback to start the next time by pressing

B

You will immediately see that the COMMANDER displays the exact time where you defined the **CU-point**.

You can set the start time as often as you like. You can also set an earlier start cue point by first pressing RESET

However, every time you set a new cue point you overwrite the previous one.

Now move the cursor to the stop time field. **◻ TIM 00:0000**

Now while the playback is running you can set the stop time in the same

way by pressing **◻ B** for the stop CU function .

Logically enough the end cue point has to always be later than the start cue point.

Now stop the EVENT by pressing **◻ ES**

Call up the EVENT again and now it will start and stop at the times you have programmed.

2.2) Start Time Update

The reset function can also be used in order to correct the start cue point to one thousandth of a second exactly during playback.

During playback move the cursor to the start time field where thousandth of seconds can be entered

> TIM 00:00◻000

Enter any value between 001 and 650 **above** the old start and press **◻ EX**

If you now press reset **◻ ←** the start time will be correspondingly later.

It's not possible to set the start time update **earlier** than the old start.

We've now shown you a few features of the HDU.

We would suggest that before reading on, you experiment with them a while.

Have fun and then go on with saving the modifications you have made.

3) Saving a Multitrack

You can create up to one hundred Multitracks with different modifications from the EVENT material available on the hard disk.

Move the cursor to the number field next to **LOAD**.

Enter a number between 00 and 99. (use 10)

Move the cursor to the left to **LOAD** and roll to **SAVE** using



Press



Are you sure ?

Press



for YES.

If you want to escape from this function press



for NO.

4) Playing Multitracks with the COMMANDER

Press



Insert the number under which you saved your **M** number. (10)

Start = 1 00:00,00

Start the playback as always with



Listen to the recording. You can stop any time by pressing



or reset the recording by pressing



5) Erasing an EVENT ,erasing a Multitrack

Move the cursor to the number field next to **LOAD** and enter the number of the **EVENT** or Multitrack you wish to erase.

Move the cursor to the **LOAD** field. Roll to **SAVE** and then to **DEL.** (delete)

using



Press



Delete Multi ?

1

Are you sure ?

1

Deleting an Event:

EX

Delete Multi ?

0

Delete Event ?

1

Are you sure ?

1

You can leave this function by using

0

6) MIDI in Page 1

A Multitrack can be loaded via Program Change Command.

Start, Stop and Reset can be executed by MIDI keys C 8, B 7, A*7.

The MIDI functions can be disabled on Page 0.

The Volume and Delay can be controlled via MIDI Exclusive Data.
(Please refer to Section H)

7) Automatic finder for M-files

To give you some help in finding back the programmed Multitracks, there is a utility on page 1, which is looking for the next higher M-file number. The multitrack is then automatically loaded and is ready for start.

Playback Multitrack 00 at first. Then press:

B

Now the next available M is loaded.

The playback can be started like normal.

Start = 1 00:00,00

If there is no higher M number found, the message

File not found !

appears in the commentary.

SECTION C

PAGE 1 Recording

You enter this Page by pressing



and



	←	Normal	EV	00	SR		
		VO	00	00	00	00	RE
		DE	000	000	ms	ES	
		>TIM	00:	00	000	PE	
		OTIM	00:	00	00		
1	Multitrack Recorder	LOAD	00	←	<input type="checkbox"/>	CU	EX

1) General Survey

Page 1 is the recording page.

Before you commence recording we strongly recommend you reading the following paragraphs since recording with the HDU demands planning and consideration.

The HDU provides 10 recording tracks since the hard disk has 10 recording heads. These heads lie parallel to each other. This means that only those tracks which belong to the same EVENT number can be played back simultaneously, and only if they start at the same moment in time .

In addition to this it is only possible to play back 4 tracks simultaneously and they must all have the same EVENT number and all start at the same moment in time.

In order to make this clear we would like to draw a comparison.

When recording on normal analog multitrack tape it is only possible to simultaneously hear audio signals which lie parallel to each other and which are on the same tape.

E.g. with the HDU one EVENT with more than one track is similar to one analog multitrack tape, and another EVENT is another analog tape.

We would like to point out that your initial recording determines the maximum length in time of this EVENT number. Additional tracks can always be shorter, but never longer.

You can, however, record 10 tracks parallel to each other , track for track (mono or stereo) , so long that each track does not exceed 72 seconds in length.

Obviously if you need fewer tracks than 10 each track can be correspondingly longer.

E.g. if you only need 5 tracks each track can have a maximum length of 144 seconds.

The HDU manages the hard disk independantly, that is you do not need to select the position in the Track Window where the Hard Disk will record.

If a recording reaches the maximum length of the Track Window it will continue recording or playback in the opposite direction.

Don't freak out!

The HDU isn't damaged, it's just that when the heads have reached one side of the hard disk they continue in the opposite direction.

2) Recording the first Track

Make a coarse adjustment of the recording input level using the rotary switch on the HDU itself and adjust the fader on your board so that the overload led on the HDU does not flash. Later an exact adjustment can be made.

Press:

The cursor automatically jumps to the minutes field of the stop time.

T I M :

Set the recording time in minutes, seconds and hundredth of seconds. After each insertion the cursor jumps automatically to the next position. However, you must complete all the values before proceeding to the next step.

Should you not be sure how long the recording is going to be write in a time longer than you actually need. You can always end the recording function by pressing

After entering the recording time values you see the cursor flashing at **EV**

Enter in any number between 05 and 99.

An arrow in the display points to the **left** for recording.

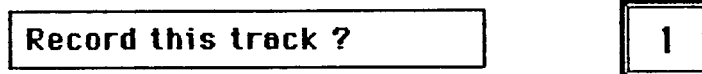

You can either record mono or stereo.

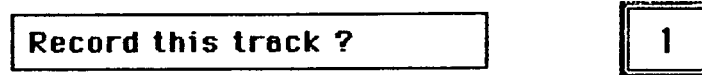

Remember, when the arrows point to the right - it means **PLAYBACK**,
when the arrows point to the left - it means **RECORDING**.

Now 2 tracks are ready for recording and the commentary says:

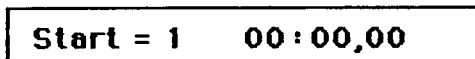

At the same time a VU meter is displayed, to allow you to adjust the input level of the recording.

Note: when the 0 db mark is reached the Input signal is clipped because of the digital conversion. When the record is starting the VU meter is replaced by the trackdisplay of page 1.

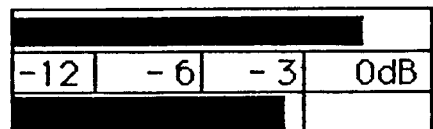

Start the recording with  or via MIDI with key C 8.

When the recording time you have determined is over the HDU will stop automatically.

You can, however, stop the recording at any time by pressing 

or via MIDI using key B 7.

3) Recording additional Tracks

Press

Enter the same EVENT number used for your initial recording.

The COMMANDER will ask you

For the tracks which you have already recorded you must obviously answer with **NO** otherwise you will be erasing these tracks!

When you answer with NO you will see that the arrow jumps to a new track.

Now you must answer with YES

Since you can record stereo the COMMANDER will offer a further track.

After having answered either YES or NO the COMMANDER will wish to know which of the already recorded tracks you want to hear played back.

If you now intend to record only one track you can hear in playback two previously recorded tracks which the COMMANDER will offer one by one. If, however, you now intend to record stereo you can only hear in playback one previously recorded track. Again answer with YES and NO.

When all is complete the following appears:

Start with:

Repeat this procedure according to how many tracks you wish to include in this EVENT number.

E.g. if you already know that you will require tracks free for material you as yet do not have, repeat the procedure no matter whether you record actual signals on to the track or not, since then the HDU knows that the tracks are not free.

This allows you the possibility of synchronizing tracks at a later date with other material.

However, it is also possible to overwrite existing tracks.

The following error messages can appear while recording:

No track available

If only one track is available but you wish to record two.

Cant take such time

If with a new recording the recording time required is longer than the time available. In this case you must either select a shorter time or erase an EVENT.

4) Recording and MIDI

The HDU receives start , stop and reset signals via MIDI and can change the tempo of the recorded material in sync with your MIDI sequencer.

What you have to do:

Connect your sequencer to MIDI IN of the HDU.

Set the HDU in a recording situation and when you read:

Start = 1 00:00,00

Start the sequence. The HDU will start recording in the same moment and either stop at the programmed stop time or start recording from that point in the sequence where a Reset Command (Bb 7) is programmed .

With this unique feature you can continue recording over and over again. Stop the sequence manually just before the position of the Reset.

The MIDI Clock is also memorized by the HDU and if you now load your playback in Page 4 you can change the tempo of the sequencer and the HDU will playback in sync without changing the pitch.

SECTION D

PAGE 4 Time and Pitch Correction

To reach this Page press  and 4

		SPEED	LOOP-MODE		
	⇒	S 00	L 50	EV 00	SR
		V 00	P 1 +	00 00	
		V 00	P 2 +	00 00	
		>TIM	00:00	00	ES
		=TIM	00:00	00	P
4	Time Manipulator	LOAD 00	←	<input type="checkbox"/>	CU EX

V 00 P 1 + 00 00

V 00 P 2 + 00 00

>TIM 00:00 00

=TIM 00:00 00

V 1 and V 2 = Volume Track 1 and Track 2

P 1 and P 2 = Pitch Track 1 and Track 2

Start and Stop Time

Intended Time for Playback

1) General Survey

On this Page you can change the speed of a playback, mono or stereo, without changing the pitch.

You can also do the exact opposite, that is change the pitch of a playback without changing the speed.

You will realize how interesting this can be when you start to combine the modifications mentioned. This means you can playback slower at a higher pitch or playback faster with a lower pitch.

Please note that due to the degree of manipulation on this Page and depending on the manipulated sound material there may occur effects which cannot be avoided.

2) Working with Page 4

Start with loading a playback by pressing

PE

Call Event

0 0

The number of tracks available for this EVENT can be seen by the number of small bars together with the flashing arrow. Now 4 tracks are available.

Playb. this track ?

Now decide using YES and NO which tracks you want to modify. A maximum of 2 can be played back on this Page.

Start the EVENT with 1 when you read Start = 1 00:00,00

You can always reset the EVENT using



On Page 4 you can, using the rotary pots, modify the Volume, Playback-Speed and Loop-Length and Pitch in Cent.

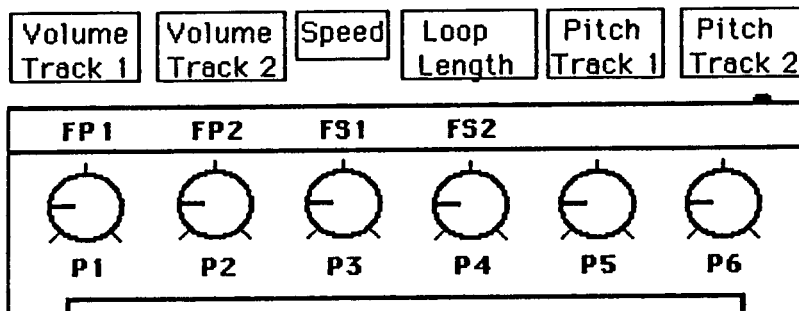

The Speed values shown on the COMMANDER (pot P 3) are relative. 50 is the normal speed of a playback. 99 is double tempo and 25 half tempo.

Please note that if a MIDI clock is running that P 3 is disabled and the speed will then be controlled by MIDI. (See Section D Time Manipulation)

P 4 has the function of adjusting the Loop-Speed according to the recorded sound material.

P 5 and P 6 can only raise the pitch to a maximum of a semitone (100 Cent).

Section D Page 2

In order to raise or lower the pitch to a greater range (+/- 12 Semitones) you must use the numerical input fields P1 and P2 :

V 00 P 1 + 00 00
V 00 P 2 + 00 00

Move the cursor to this position and insert any number between 00 and 12.

V 00 P 1 + 00 00
V 00 P 2 + 00 00

Using this input field you can decide whether you raise or lower the pitch. Use the +/- keys to do this.

The result will be audible when you either enter a new value into the semitone field or simply by pressing

EX

For defining the start and end cue points of the audio material you want to manipulate in time use the CU function.

During the playback is running move the cursor to the Start and Stop time field, roll to

>TIM 00:00 00

and set the start time by pressing

B

and then roll to

0TIM 00:00 00

and set the stop time by pressing

B

Experiment and have fun using these various functions.

3) Time Manipulation

The HDU provides three methods of Time Manipulation of previously recorded material. They are:

3.1 Using P 3

3.2 Using MIDI

3.3 Using a Predetermined Playback Time

Please note that the fine adjustment of the Loop Algorithm (Loop-Length) can be used in all of these methods. (Controlled by P 4)

3.1 Using P 3

Rotary pot P 3 controls the speed manually .
This function is disabled when a MIDI clock is running.

3.2 Using MIDI

The speed of the playback can be controlled via MIDI clock from a MIDI Sequencer. This unique feature of the HDU provides you with the possibility of a later speed adjustment of the recorded audio material in sync with a MIDI sequencer.

3.3 Using a Predetermined Playback Time

This function allows you to play back a recording of, let`s say, 60 seconds in, let`s say, exactly 58,4 seconds.

Move the Cursor to this position: = T I M :

and insert the desired value in minutes, seconds and hundredth of seconds.

If you insert a certain value for playing back with a predetermined playback time the HDU will calculate the new speed using the time between Start end Stop time cue points.

4) Saving a Multitrack with Pitch and Time Manipulation

All manipulations which are described above can be saved as a Multitrack file.

All you have to do is, move the cursor to the number field next to LOAD, insert a two digit number between 00 and 99, move the cursor to LOAD, roll to SAVE using the "+" key and press

Remember that the total of Multitracks you can have is 100. That means you should not use numbers for saving a new Multitrack which have been used already to save a Multitrack in Page 1.

However, you can load any Multitrack in any of the two pages **Page 1** and **Page 4** by simply pressing  and the required number.

If you e.g. load a Multitrack in Page 1 which was saved in Page 4 the display will automatically change to Page 4 and vice versa.

5) MIDI in Page 4

Via MIDI you can control the pitch by MIDI keys and Mod. Wheel and the speed of a playback through the MIDI Clock. The HDU also can play in sync with a MIDI sequence even if you change the playback speed at the sequencer !

The HDU receives Program Change Commands via MIDI and will load a Multitrack if you have entered a program number on your MIDI keyboard.

The display shows



You can now start the playback with the COMMANDER by pressing



or you can send a start signal by starting a MIDI sequencer (FA hex).

When the sequencer is running and sending out MIDI clocks (F8 hex), the HDU on page 4 will follow the speed of the sequencer. This unique feature allows you to synchronize vocals or a guitar solo to the rhythm tracks of your sequencer even when changing the speed afterwards.

Note: For using this feature you have to connect the sequencer to the HDU while recording, because the MIDI clock is saved together with the audio material at the same time you record in sync with the sequencer.

When the sequencer is stopped (sending out FC hex) the Playback of the HDU will also stop.

NOTE: START, STOP, and RESET can be executed by key ON events

Key Bb 7 = Reset
Key B 7 = Stop
Key C 8 = Start

These key ON events can be disabled on Page 0.

SECTION E

PAGE 2 Realtime Effects

Please enter this Page by pressing  and 2

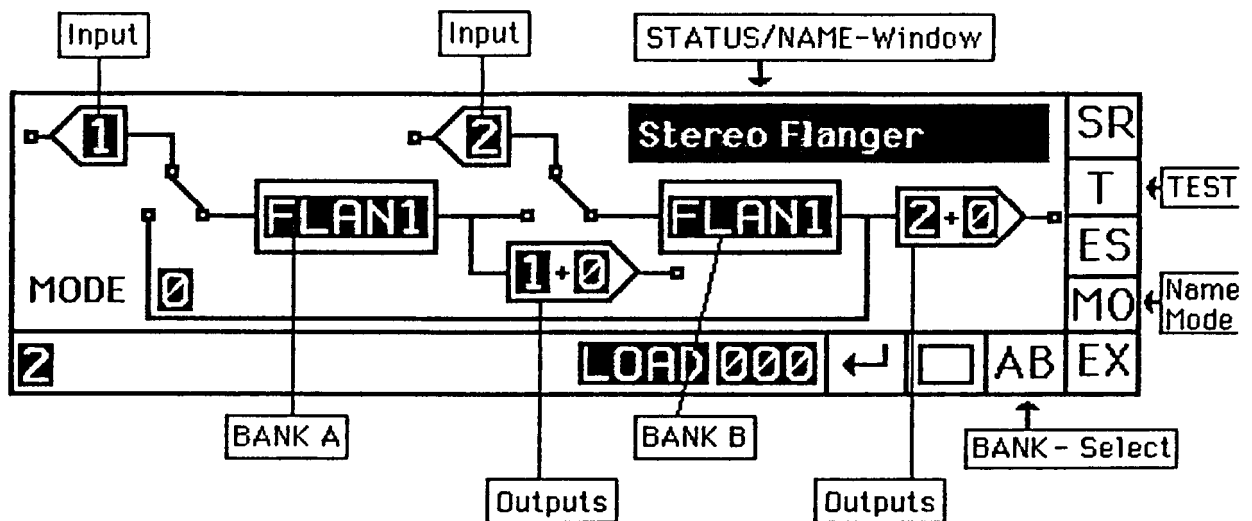

1) General Survey

Please connect a CD player or tape recorder to the HDU inputs to hear the effects.

Call Arrangement "5" by pressing P 005 and you will hear a stereo flanging effect.

Insert P 000 and you will hear the original sound from tape or CD.

This Page offers a total of 1000 Arrangements (000 - 999).

The Arrangements P 000 to P 049 are presets which cannot be erased and always are loaded after power on or reset of the HDU.
(see listing on page 5 of this section Section)

The Arrangements P 050 to P 999 are user programs.

This Section describes the following features on Page 2:

- The Effect Pages for Echo, Phasing, Flanging, Distortion, Harmonizing and Filter
- The Effect Routing (parallel, serial, independant)
- The Input and Output Routing

Each effect like Echo, Distortion etc. can be stored on the corresponding Effect page using Programs 10 to 59.

Programs 00 to 09 are single effect presets.(also loaded at reset).

An Arrangement will be loaded with the following information :

- The Routing Mode
- Which kind of effect is loaded into the two effectbanks
- Which effect program numbers are loaded for these effects
- The input assignment of the HDU (0=off, Inputs 1 and 2)
- The output assignment (0=off, Outputs 1,2,3 and 4)

Use the **TEST** function to hear any modification which you have done on Page 2.

Example:

Move the cursor to the Input symbolfield. Insert "0" and press



Now one input channel is off.

In the same way you can change the output assignement. Do some modifications and verify with **TEST**.

Note: It is not necessary to use the **TEST** function when you call a new Arrangement with the **P** (Program) key in the keypad.

Please now make yourself familiar with the routing possibilities:

Move the cursor to the number field next to **MODE**.

Insert "1" then "2" and then "0". You can see in the display that the routing configuration is changing. Here are the meanings of the different routing modes:

MODE 0 = **two external** signals are coming in independantly and **parallel** through the HDU

MODE 1 = **one external** signal is send through both effect banks

MODE 2 = **one external** signal can be recorded on to the hard disk with an effect

MODE 3 = **one internal** signal (playback) is played via an effect and recorded in the same time on to another track (Resampling)

2) Selecting different Effects

Press key in the keypad.

You will see the cursor flashing in one BANK field.

Press key again.

Now the cursor is flashing in the second BANK field.

Use the key in the keypad to select the different effects.

If you want to see the corresponding Subpage to the selected effect simply

press

If you want to return to Page 2 please press and "2"

Please note that the Pitch-Transposer needs both Banks and that the corresponding Page can only be accessed from Bank B. To avoid missettings the roll-fields are locked when "Pitch-Trans" is set. Please load another arrangement to disable these fields.

3) Saving Programs and Arrangements

The procedure is the same as in the other Pages.

Move the cursor to the number field next to LOAD. For saving an Arrangement use number 050 to 999, for saving an effect program on the corresponding Effect Page use number 10 to 59. If you have made changes on the Effect setting you have to save this on the Effect Page. If you save the new effect setting under a new number you have to save the Arrangement afterwards.

Move the cursor to LOAD roll to SAVE (Using the +/- keys) and press

Important Note:

Your Arrangements and all effect programs are now only stored in the working memory. To save them permanently you have to copy them from the memory to the Winchester drive.

Go to Page 0 and move the cursor to the field **LOAD OLD WORLD**. Roll to **SAVE NEW WORLD** and press EX.

The terms Old World and New World are used because this file contains all important user update data (except EVENTS, Multitracks and Songs).

3) Names function on Page 2

As you may have noticed all Arrangements display a name in the Name Window.

You can also name your own Arrangements.

Move the cursor to the Name Window and press:



Using the VERT CURSOR you can select letters and numbers.

Confirm the selected letter with:



Using the key  you can select small letters and signs.

The zero position of the VERT CURSOR is used for "Space".

Use key  for backspace.

Please don't forget to save your Arrangement with the name as described above.

4) MIDI on Page 2

An Arrangement can be called with the Program Change command via MIDI.

Besides that it is possible to control all parameters on the Subpages via MIDI exclusiv data. Please refer to Section H.

List of Presets P 000 to P 049

NR	Name
P 000	Direct through
P 001	Echo
P 002	Echo quadro out
P 003	Stereo Delay
P 004	Stereo Filter
P 005	Stereo Flanger
P 006	Stereo Distortion
P 007	Distortion/Filter
P 008	Direct through
P 009	All off
P 010	not valid
P 011	Pitch Transpose / Mono
P 012	
P 013	Stereo Phaser
P 014	Stereo Phaser
P 015	not valid
P 016	Lesly
P 017	Echo / Phaser
P 018	Reserved
P 019	Reserved
P 020	Stereo Filter
P 021	Stereo Filter
P 022	Stereo Filter
P 023	Flanger / Echo
P 024	Flanger / Distortion

NR	Name
P 025	Flanger / Phaser
P 026	Double Flanger
P 027	Phaser / Filter
P 028	Filter / Phaser
P 029	Reserved
P 030	Reserved
P 031	Reserved
P 032	Resampling Pitch Transpose
P 033	Playback via Effect Pitch Tr.
P 034	2 - Track Mixdown
P 035	Resampling Echo
P 036	Resampling Phasing
P 037	Resampling Flanger
P 038	Resampling Distortion
P 039	Resampling Filter
P 040	Record via Effect Echo
P 041	Record via Effect Phasing
P 042	Record via Effect Flanger
P 043	Record via Effect Distortion
P 044	Record via Effect Filter
P 045	Playback via Effect Echo
P 046	Playback via Effect Phasing
P 047	Playback via Effect Flanger
P 048	Playback via Effect Distort.
P 049	Playback via Effect Filter

Page 2 Echo

You enter this Page by pressing **B** on Page 2 then using **+**
 to select ECHO1 and then **T** **EX**

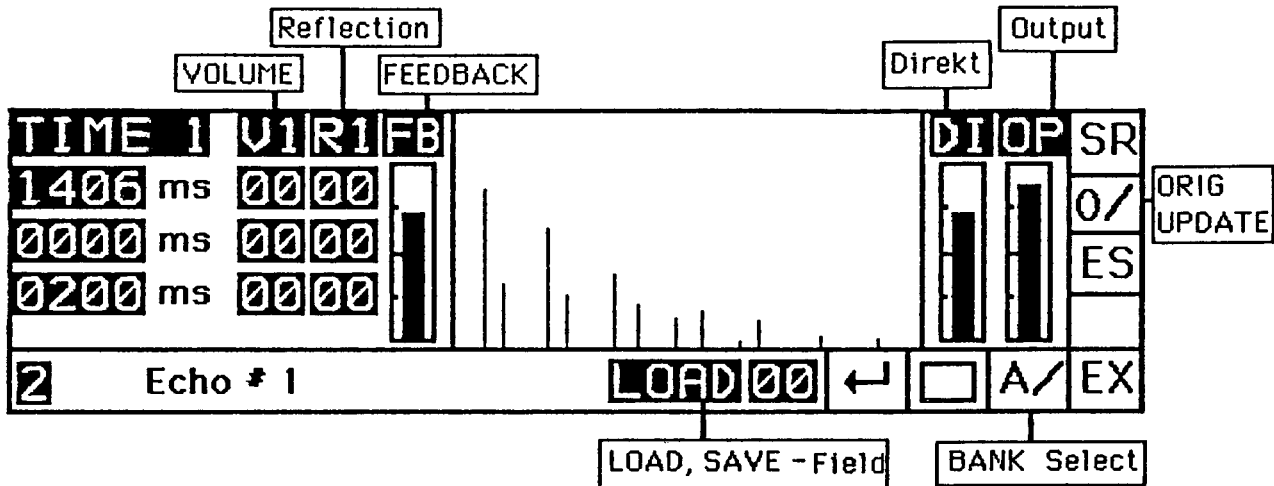

The abbreviations on the Echo Page are used as follows:

TIME : Time 1, Time 2 and Time 3 are available. Move the cursor to TIME

and press **+**

Use P 1 to modify the value in milliseconds or enter a number numerically or the "+/-" keys in the keypad.

- V** = Volume of the Echos modified with P 2
- R** = is the amount of reflection for the corresponding echo changed by P 3
- FB** = Total feedback for relections 1, 2 and 3. Use P 4
- DI** = Mixing the direct signal to the modified signal. (P 5)
- OP** = Total output level (P 6)

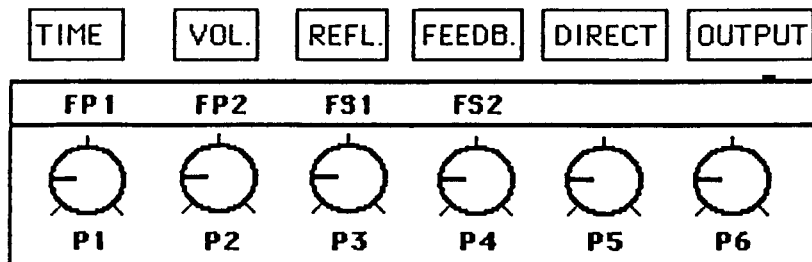

Use Programs P 10 to P 59 to save your own programs. (P 00 to P 09 are Preset effect programs.)

Use the  key to switch between your modifications and the original.

Page 2 Phasing

Enter this Page and the following Pages in the same way as described for the Echo Page.

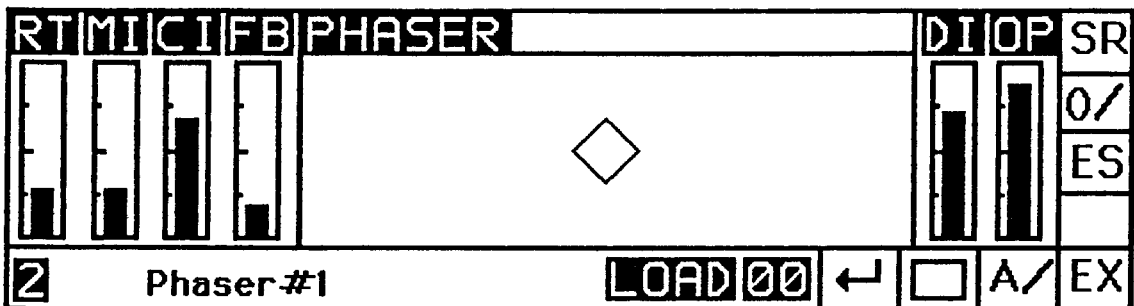

The Phasing offers the following features:

RT = Rate (LFO) modified with P 1

MI = Modulation Intensity (LFO drives the effect) P 2

CI = Constant Intensity of the effect (P 3)

FB = Feedback modified with P 4

DI = Direct signal (P 5)

OP = Total output level (P 6)

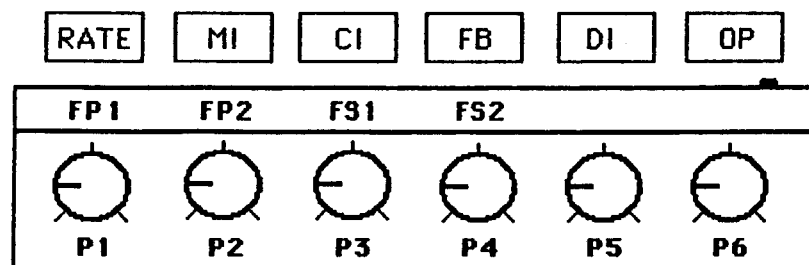

Page 2 Flanger

As you can see in the display the Flanger comes with the same picture as the Phasing Page. All the functions are the same but not the effect.

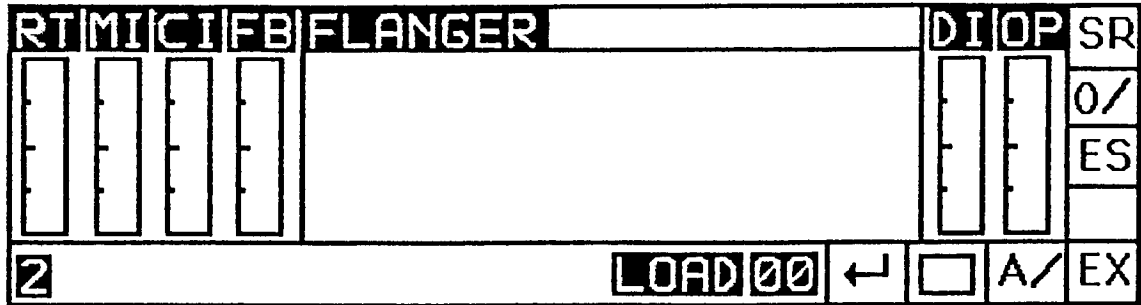

Use the  key to switch between your modifications and the original.

Page 2 Distortion

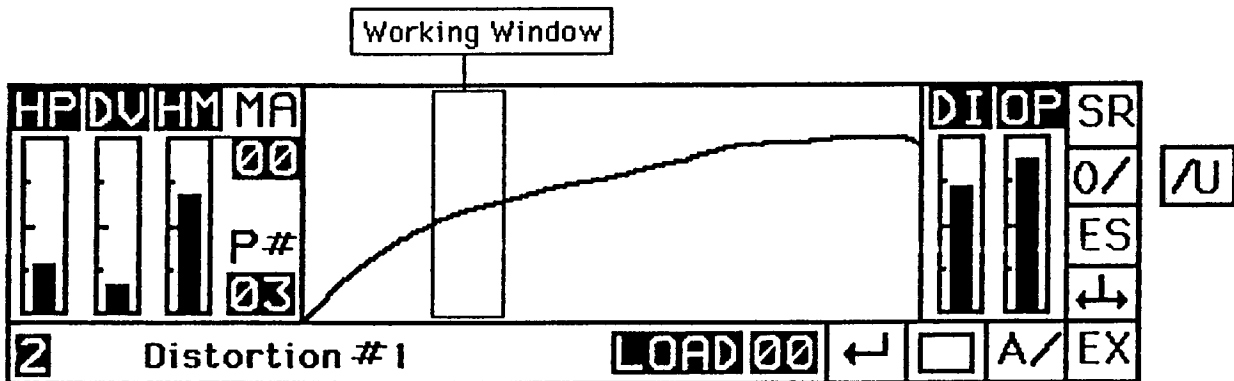

With this Page you can simulate the characteristics of amplifiers. You can create your own types of distortion by drawing the curve in the COMMANDER display.

With the drive control(DV) it is possible to change the input level and thus control the amount of distortion.

If the first segment of the curve is horizontal and a low signal is being used the output signal will be zero and you will get a noise gate effect. Using the Drive and Highpass you can get a kind of Aphex effect.

Section E Page 8

For a fast modification of the curve press the key



and you will see



Now the HOR CURSOR moves the Working Window from Point 1 to 16.
Use rotary pot P 4 to change the magnitude.

To get back to the normal cursor function press the key



and you see again



On this Page the parameters are:

HP = Highpass Filter (P 1)

DV = Drive (P 2)

HM = Harmonic amplifies the odd or even numbers of the harmonics.
(P 3)

MA = Magnitude of the distortion curves` 16 points. (P 4)

P * = Parameter Number 1 to 16 selected by the HOR CURSOR.

DI = Direct Signal (P 5)

OP = Output Level (P 6)

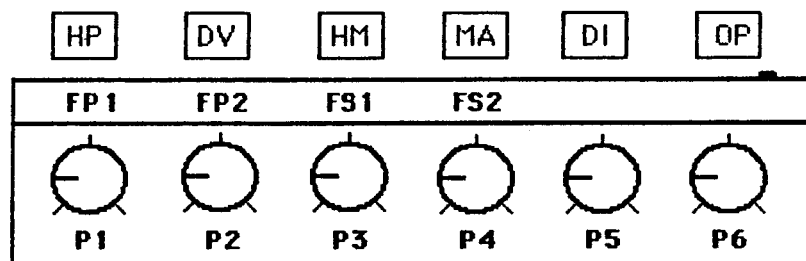

Page 2 Filter

Enter this Page as described above.

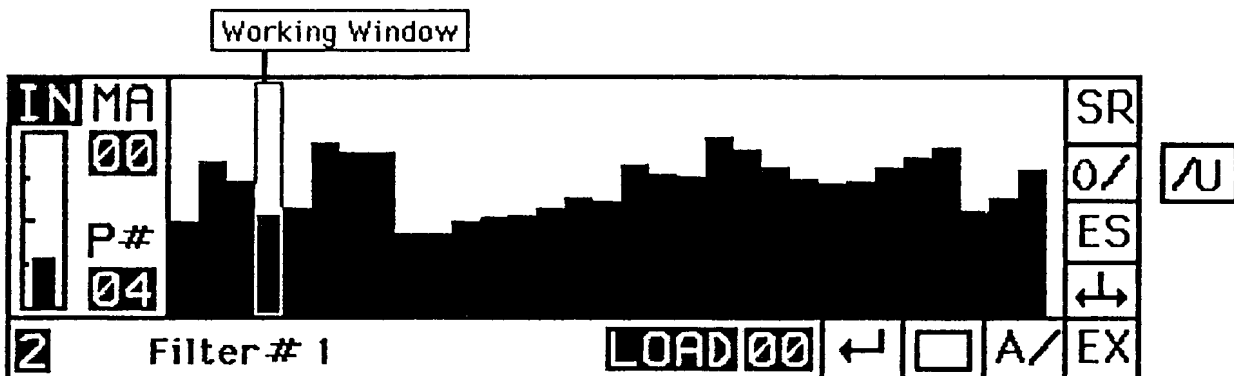

This is not a parametric equalizer. It is a digital F.I.R. Filter and the 31 parameters correspond to a chain of delays which are amplified in volume using the magnitude of each parameter.

IN = Input Level (P 1)

MA = Magnitude (P 2)

For accessing fast modification of the parameters press the key



and you will see



Now the HOR CURSOR moves the Working Window from Point 1 to 31.
Use rotary pot P 2 to change the magnitude.

To get back to the normal cursor function press the key



and you see again



Page 2 Harmonizing

You can enter this Page in two ways:

-By calling Arrangement P 011 on Page 2 and pressing EX on Bank B!

-By rolling to TRANS when the cursor is flashing on Bank B and

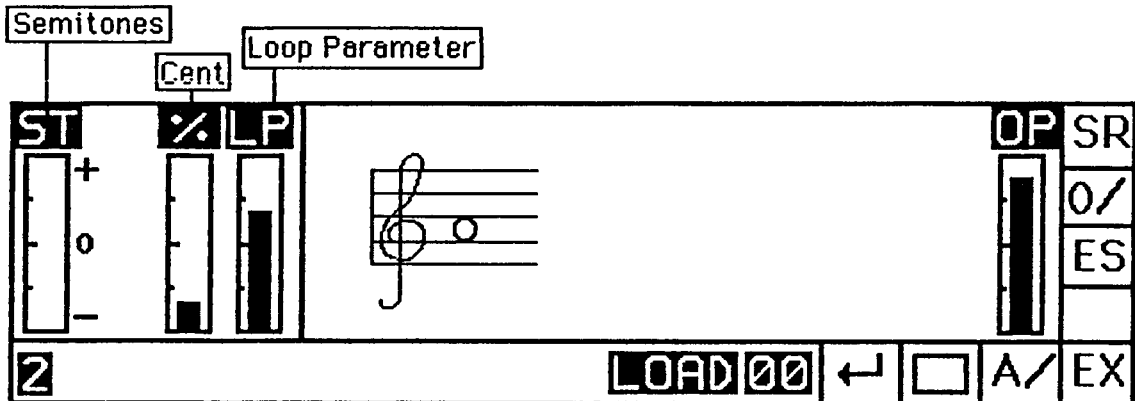

P 1 = Semitones (one octave up and one octave down)

You also have a visual control via the graphics. When you turn P 1 you will see that a second note appears which shows the current interval. When you now move the note back to the "a"-line, the note disappears. Don't worry, now you have selected no interval but you can detune the sound material in Cents.

P 2 = Cent (hundredth of a semitone)

P 3 = Loop Parameter (Speed of the Loop Algorithm)

P 4 and P 5 have no function on this Page

P 6 = Output Level

Harmonizing can only be used mono.

In case you need stereo harmonizing please use Page 4 or the Resampling track by track.

SECTION F

Page 2 Resampling - Mixdown

This Section contains another 4 possibilities of working with the HDU:

- 1) Playback of one Track via effect
- 2) Recording an external source via effect
- 3) Playback and recording of one Track via effect (Resampling)
- 4) Mixdown of two Tracks

Please note that Resampling and Mixdown are internal procedures and you do not send the signal through DA or AD converters, i.e. the signals always stay on the digital level and there is no noise added even if you repeat these features many times.

1) Playback of one Track via effect

To reach this function all you have to do is calling one of the presets P 045 to P 049.
These preset Arrangements set the necessary routings automatically.

Go to Page 2 and press P and the number 047.

The display shows this:

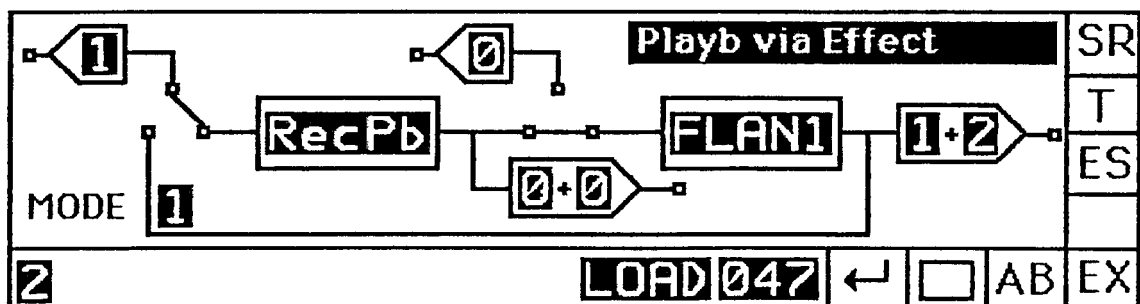

In Bank A you see the symbol **RecPb** which stands for Record-Playback.

In Bank B you can see the current effect program (in this example Flanging.)

To change the effect simply call another Arrangement e.g. P 048 for playback via Distortion.

Now go to Page 1 and load an EVENT using PE (Play EVENT) as described in Section B.

In the Status Window you read Playb>Eff.

Please note that calling a Multitrack with the P will set the status back to NORMAL and you will leave the "Playback via effect" status.

Only one Track can be used .

After selecting the desired Track the display changes to the corresponding effect Page and you see:

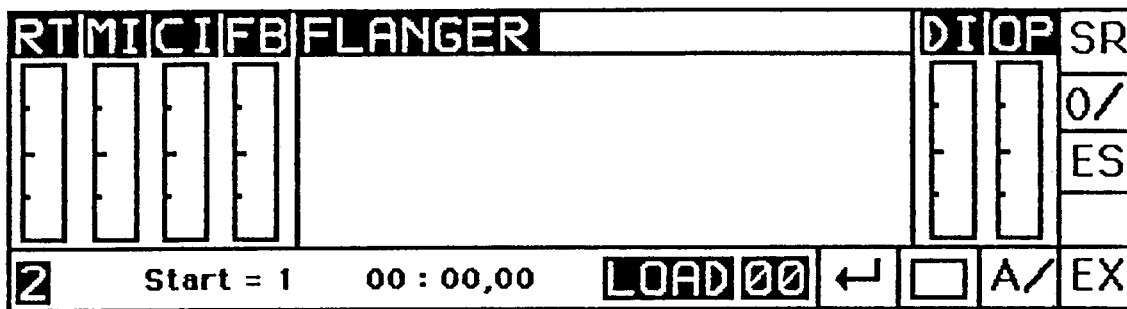

Start as usual with



Modify the sound manually or call one of the Programs P 00 to P 59.

Also in this Page the key



has the Reset function when the playback is running.

2) Recording an external source via effect

Use preset Arrangements P 040 to P 044 to call the different effects and to prepare the routing.

Load P 042 in Page 2.

You will see the following display:

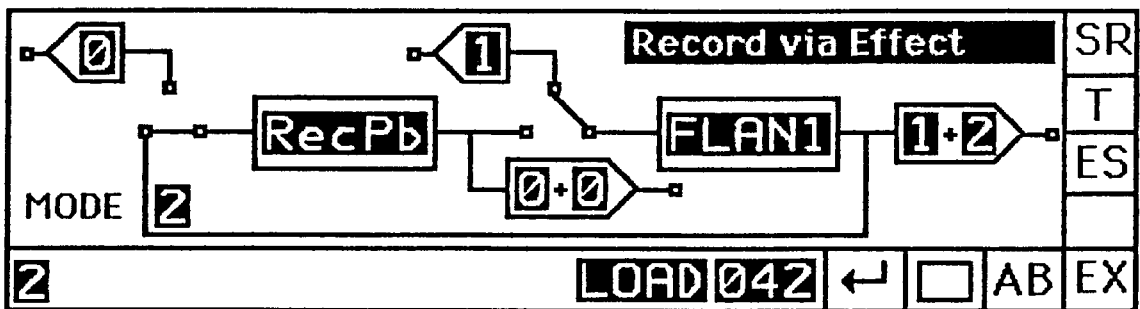

Go to Page 1 and select RE (if necessary please refer to Section C Recording)

Since one processor is busy with producing the effect you can only record one Track.

After defining the recording Track the effect Page shows up again with the comment:

Start = 1 00:00,00

Start with

1

Let the recording start from the beginning with



Please note that it is not possible to record via Harmonizing

3) Playback and recording of one Track via effect (Resampling)

For Resampling preset Arrangements P 035 to P 039 are available.

Call P 037 on Page 2 and you see:

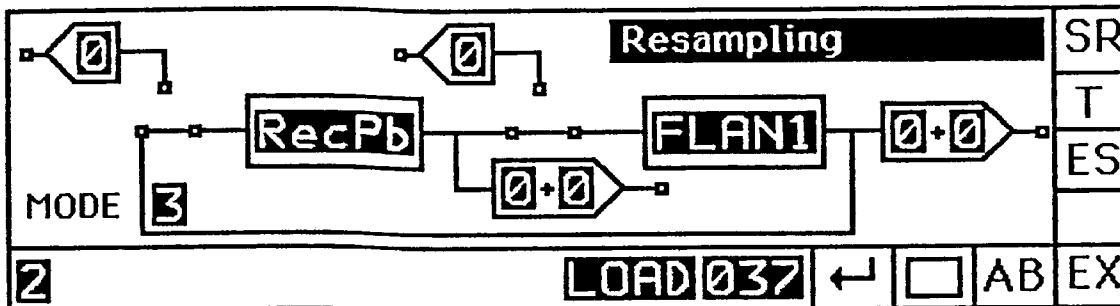

Go to Page 1 and insert

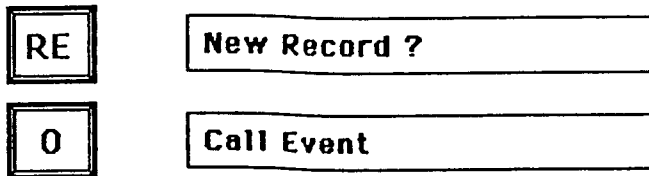

Call the EVENT you want to use for Resampling.

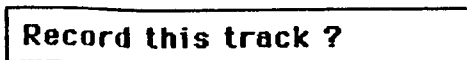

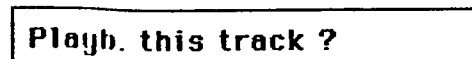

Decide which Track you want to record on. You can overwrite existing Tracks or if you keep answering with NO the COMMANDER will offer a new Track in addition to the already existing Tracks (If there is enough space)

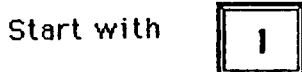
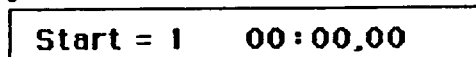

Now you decide which Track is played back, that means which Track is sent through the effect program.

Right after selecting the playback Track the COMMANDER offers the effect Page with the commentary:



Use  to reset the recording to the beginning.

4) Mixdown of two Tracks

For Mixdown please call Arrangement P 034 .

The COMMANDER display shows:

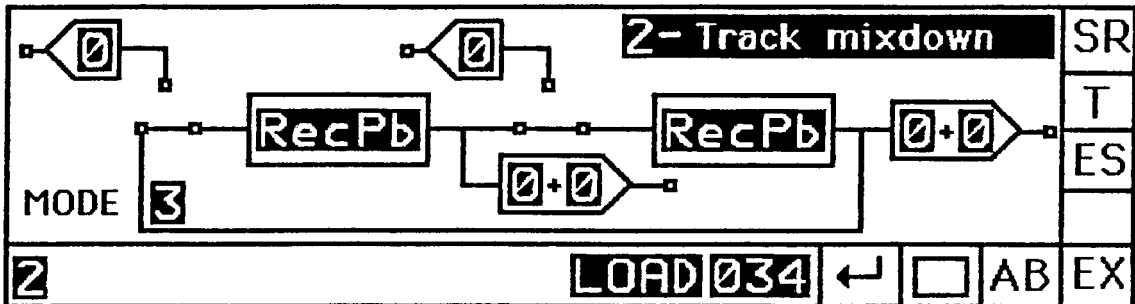

Now the routing is made and you have to do following on Page 1:

RE	New Record ?
0	Call Event

Select an EVENT

First you define which will be the new Track where the two mixed signals are recorded.

Record this track ?	use NO and YES for selection.
---------------------	-------------------------------

After selecting the recording Track the COMMANDER asks:

Playb. this track ?

Now define two Tracks which are to be mixed together using YES and NO.

Then the commentary displays :	Start = 1 00:00,00
--------------------------------	--------------------

Start with

1



For mixing use the rotary pots P 1 and P 2. Remember that you always can start the mixdown from the beginning with the reset function.

Naturally enough there has to be space available on the Hard Disk for mixing down.

SECTION G

Page 3 Song Editor MIDI

Enter this Page by pressing  and "3"

		Song Position			Blend			
COMMENT	NO	M	T #	BEAT	msec	BLD	SR	
							T	
							ES	
		00	M	00	0000	0000	000	MO
	Song Editor	MIDI		LOAD	02			EX

1) General Survey

This Page is used for creating a chain of Multitracks.

When you use Mono or Stereo Multitracks made on Page 1 the HDU will load the next M while the current playback is running. This allows you at any timepoint to start a new M while the current M is played back. This means it is possible to trigger or manually start a new playback at any point in the middle of a running playback. Of course this feature can also be used for cutting applications.

.(Please refer to chapter "Page 3 Digital Cutting")

Every time the display shows :

Start = 1 00:00,00

the next Multitrack can be started by either using the "1" in the keypad or by triggering via MIDI.

The Song Editor gives you fast access to all your Multitracks.

Please note:

The following multitrack settings can't be patched together directly and therefore always need to be stopped before the next M is ready for start:

Multitracks which playback three or four tracks

Multitracks which have Delay setted greater then zero

Multitracks with Time Manipulation (Page 4)

These kind of Multitracks are called "**incompatible**" in the following.

Multitracks which playback only one or two tracks, without delays setted and made on Page 1 can be patched directly together without gap and with the possibility of having crossfades.

These kind of Multitracks are called "**compatible**" in the following.

When a multitrack is stopped either manually or in fact of the stoptime defined in the M-file, the shortest pause between the two Multitracks is about 2 seconds .

When the same Multitrack is repeated or when you use only multitracks of the compatible category, the HDU preloads the next Multitrack **during** playback **immediately** after the start of the current M-file.

The time to preload a stereo Multitrack during playback is about 3 to 4 seconds.

When using a sequencer the start points can be defined with the BEAT number of a sequence.

Example:

Let's say the Introduction of your composition is 16 bars long in 4/4 time and you want the HDU to start with the vocal part. 16 bars times 4 equals 64 BEATS. In this case you have to insert BEAT number 0065 as starting point.

The HDU will also follow MIDI Song Position Commands, that means the song can be started at any point and the HDU also starts at exactly the same position and plays back the audio tracks.

Please note that due to the loading time of about 4 seconds during playback it is strongly recommended not to call a Song Position on your sequencer within these 4 seconds after the last start position because there is not enough time to preload the next Multitrack.

In case you don't know the BEAT number you can define the starting position for each Multitrack of the Song in realtime when the MIDI sequence is played back.

The number of Songs available is 6 (P 01 to P 06) each Song may have 64 parts.

2) Creating a Song

Move the cursor to the NO field. The first position of the Song is 00.

```
00 M00 9999 0000 000
```

Move the cursor to the MT field and insert a Multitrack number.

```
00 M00 9999 0000 000
```

Move the cursor to the BEAT field and insert the beat number where you want the HDU to start the playback in your sequence.

If you want to define the exact beat number later use now 9999.
(0000 means end of the entire song).

```
00 M00 9999 0000 000
```

The field msec is used later for delaying the starting point if necessary.

```
00 M00 9999 0000 000
```

The field BLD is used later for blending the cutting point.

```
00 M00 9999 0000 000
```

Move the cursor back to the NO field and insert 01

```
01 M00 9999 0000 000
```

The first line moves one step up and now you can continue inserting the next Multitrack etc.

```
00 M00 9999 0000 000  
01 M00 9999 0000 000
```

You also can use the "+/-" keys for incrementing or decrementing the values.

3) Manual Playback of a Song

Reset the NO field to position 00. Now press



The HDU will load the first Multitrack and the commentary displays:

Start = 1 00:00,00

It is also possible to start with any other Multitrack in the Song.

Example:

Roll to NO 06 and press TEST and the HDU will load the corresponding Multitrack.

Note:

When there are incompatible M-files and a sequencer starts the playback of the HDU it is important that there is enough time to let each Multitrack play up to the programmed end point to ensure that the next Multitrack starts at the right time. Or that a stop command is send at least 2 sec before the next start signal. (key B 7)

However, at any time you can stop the current Multitrack by pressing or via MIDI key Bb 7.

If you want to leave the playback of the Song before the last Multitrack

has been played press



twice.

4) Saving a Song

Move the cursor to the number field next to LOAD and use a number between 01 and 06. Note that 00 defaults to 01.

Move the cursor to LOAD and roll to SAVE with the "+" key.

Press



Are you sure ?

Press



to confirm the function.

5) Setting Cues and playing controlled by a MIDI Sequencer

Load a Song by using **P** and a two digit number or create a new song.

Now you see:

Start = 1 00:00,00

Connect the MIDI sequencer to MIDI IN of the HDU and **start** the sequencer.

Now you start the first Multitrack using key

1

at the position where you want it to play back later automatically.

The HDU memorizes the corresponding BEAT number as well as the additional Delay for each Multitrack start point.

When the Song is finished or terminated through a sequencer STOP the values appear in the display.

Save the Song with the new cues.

Load the Song again and start the MIDI sequence when the display shows:

Now the HDU will play back all the Multitracks at the programmed cue points.

For fine adjustment of the starting point please use the field msec.

6) Comment Line

Each position of a Song can be named with a comment.

Roll to the Comment field and press



Now, using the VERT CURSOR you can select letters and numbers . Each letter is entered with EX.

If you want to change to small letters please press



If you want to change back press



again.

The zero position of the VERT CURSOR is used for "space".

You can terminate the comment function at any time with the key



Don't forget to save the Song with your comments again.

Page 3 Digital Cutting

	Song Position			Blend			
COMMENT	NO	MT#	BEAT	msec	BLD	SR	
	00	M 00	0000	0000	000	T	
	01	M 00	0000	0000	000	ES	
	02	M 00	0000	0000	000	MO	
3	Song Editor MIDI			LOAD 02	←	□	EX

1) General Survey

The feature of chaining Multitracks is also used for digital cutting.

However, only compatible M-files can be used. (see chapter general survey)

The "Blend" feature is used to avoid noise at the cutting point and to get smooth transitions.

You can adjust the blending depth over a range of 000 to 500 msec.

The exact values can be entered via the numerical keypad or using the +/- keys.

2) Example of Cutting

1) Record the sound material on to the hard disk using page 1.

2) Define the exact start point of the playback by using the cue function on page 1. Note that the startpoints are also the cuttingpoints later in the song.

3) Save the single parts as Multitracks. The shortest possible time for any one Multitrack is 5 seconds if you want to avoid pauses between the individual Multitracks.

4) Go to Page 3 and build a chain of these Multitracks as described above. Use the blend function.

Section G Page 8

5) Press Test and the display will show:

Start = 1 00:00,00



After starting the playback the HDU will immediately preload the next Multitrack and as soon as you can see **Start = 1** the next Multitrack is ready to be started.

To achieve perfect results in timing and reproduction it is necessary to use an external clock or the internal clock on Page 5.
Define the cues as described above (Page 3 /5).

Once the cues are defined you can move the cutting position in steps of milliseconds.

Page 5 Song Editor SMPTE

Enter this Page by pressing  and "5"

COMMENT	NO MT#	h	mn	sc	fr	bt	BLD	SR
								T
								ES
		00	M00	00	00	00	00	MO
5	Song Editor	SMPTE	LOAD	02				EX

1) General Survey

This Page is similar to Page 3, but it is based on TIME instead on the MIDI clock. That means that the time raster is not depending on the speed of a sequencer but always is rastered in hours, minutes, seconds, frames and bits.

Note:

The SMPTE reader is a hardware option of the HDU. If the hardware board is not installed in your HDU the Page 5 only works in the INTERNAL CLOCK Mode. However, the basic functions of Page 5 are in both cases the same.

2) Creating a song: is done the same way as on Page 3. (Refere to section G, chapter 2)

3) Setting Cues and playing back a song on Page 5.

Load the song by using  and the two digit number or create a new song.

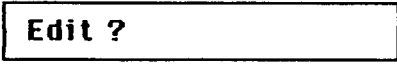
The HDU display shows now: 

You now have to decide if you want to edit cue points or just want to

listen to a song without editing. For now press 

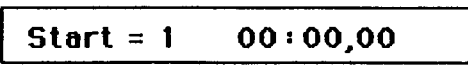
Now you see: 

You start the first Multitrack by entering a 

Every time the display shows

Start = 1 00:00,00

you can start the next Multitrack by pressing



The HDU memorizes the setted cue points and after the playback of the song displays the measured time values.

For fine adjustments of the starting points please use the BIT fields.

Enter this Page by pressing  and "5"

COMMENT	INT	NO	MT#	h	mn	sc	fr	bt	BLD	SR
										T
										ES
										MO
5	Song Editor	SMPTE								EX

1) General Survey

This Page is similar to Page 3, but it is based on TIME instead on the MIDI clock. That means that the time raster is not depending on the speed of a sequencer but always is rastered in hours, minutes, seconds, frames and bits.

Note:

The SMPTE reader is a hardware option of the HDU. If the hardware board is not installed in your HDU the Page 5 only works in the INTERNAL CLOCK Mode. However, the basic functions of Page 5 are in both cases the same.

After powering up the HDU Page 5 is initialised for use with the internal clock. If you want to work with external SMPTE sources, you have to change the roll field in the top line of the display from "INT" to "EXT".

2) Creating a song: is done the same way as on Page 3. (Refer to section G, chapter 2)

3) Setting Cues and playing back a song on Page 5.

Load the song by using  and the two digit number or create a new song.

The HDU display shows now: 

You now have to decide if you want to edit cue points or just want to listen to a song without editing. For now press 

Now you see:

Start = 1 00:00,00

You start the first Multitrack by entering a

1

Every time the display shows

Start = 1 00:00,00

you can start the next Multitrack by pressing

1

The HDU memorizes the setted cue points and after the playback of the song displays the measured time values.

For fine adjustments of the starting points please use the BIT fields.

Note:

If the SMPTE hardware option is installed in your HDU, the unit is able to work in the chase Mode: That means if the external SMPTE source is starting to send out the time code the HDU will load the corresponding soundmaterial and drop in as soon as possible.. This works only in normal playback mode (EDIT=0=OFF).

For editing the Cue points the HDU must be in Edit mode (EDIT=1). If you want to work in the Chase mode after an Edit run you have to press

T

and when the question

Edit ?

appears :

0

SECTION H

MIDI of the HDU

Connect your sequencer or MIDI Keyboard MIDI OUT with MIDI IN 1 or MIDI IN 2 of the HDU.

After Booting, MIDI Channel 1 is set automatically and the following MIDI Commands will be active:
(Please enter Page 0)

MIDI channel 01		SR
Program change (Cn)	1	
Real Tim (F8,FA,FC)	1	
Note on (9n) P 4	1	ES
Note on (9n) > 0 ←	1	
000 MIDI SETUP	LOAD OLD WORLD	EX

1) General Survey

The MIDI Channel can be selected with rotary pot P 1.

Please note that all changes made on this Page must be confirmed with **EX!**

Program Change enables (1) or disables (0) calling Multitracks on Page 1 and Page 4 and calling Arrangements on Page 2.

Real Time (On/Off) Here you can enable or disable a MIDI Clock coming in i.e. when Realtime is Off (0) the MIDI Clock will be ignored and pot P 3 on Page 4 can control the playback speed

Note on Page 4 enables or disables changing the pitch via MIDI keys

Note on Start, Stop, Reset enables or disables the keys C8, B7, A*7

which are used to start, to stop and to reset the HDU's playback via keyboard or MIDI Sequencer.

If you want to synchronize a guitar to your MIDI sequence do the following:

Define the Track you want to record on Page 1 and set up the HDU until you

see:

Start = 1 00:00,00

Then start the sequencer and the HDU will start at the same time via MIDI start command.

If you afterwards want to run the HDU playback in circle in sync with your sequencer we recommend you using a recording time which is a little longer than the actual sequence.

This allows you to program a reset (A*7) at the beginning of your sequence which will cause the HDU to reset the playback every time, the sequencer is playing the loop. The same way you can proceed when in the record mode.

2) MIDI Exclusive Parameter List

If your MIDI keyboard or MIDI Sequencer is able to send out MIDI Exclusive data you have access to all parameters of the HDU (e.g. automation mix...)

However, you have to be on the corresponding Page which you want to control via MIDI.

The Format of the Exclusive Parameters is:

11110000	Status Byte	(F0 H)
0 iiiiii	Identification number of PPG	(29 H)
0sssnnn	Substatus (s=2) Channel number	(n=0-15)
0mmmmpp	Modell (m=3) parameter bit 7,8	(p=00)
0pppppp	Parameter bit 0-6 (Contr * see list)	(p=0-30)
0dddddd	Parameter value data	(d=0-127)
11110111	EOX	(F7 H)

3) MIDI Exclusive Page 1

Page 1 receives **All notes off Command**

Delay 1 Contr #04
Delay 2 Contr #05

Volume 1 Contr #00
Volume 2 Contr #01
Volume 3 Contr #02
Volume 4 Contr #03

4) MIDI-Exclusive Page 4

Volume 1 Contr #0
Volume 2 Contr #1

Semitones 1 Contr #06
Semitones 2 Contr #07

Cent 1 Contr #04
Cent 2 Contr #05

Pitch-Wheel Contr #40

Speed Contr # 02

5) MIDI Exclusive Page 2 Echo

Delay 1 coarse Contr #03
Delay 1 fine Contr #06

Delay 2 coarse Contr #04
Delay 2 fine Contr #07

Delay 3 coarse Contr #05
Delay 3 fine Contr #08

Volume 1	Contr #31	
Volume 2	Contr #32	
Volume 3	Contr #33	
Direct	Contr #34	
Reflection 1	Contr #26	
Reflection 2	Contr #27	
Reflection 3	Contr #28	
Feedback	Contr #30	
Freeze	Contr #41	or Mod Wheel
Output	Contr #35	

6) MIDI Exclusive Page 2 Phasing

Rate	Contr #08
Modul Int	Contr #07
Constant Int	Contr #05
Feedback	Contr #29
Direct	Contr #35
Output	Contr #36

7) MIDI Exclusive Page 2 Flanging

Rate	Contr #08
Mod Int	Contr #07
Constant Int	Contr #05

Feedback	Contr #29
Direct	Contr #35
Output	Contr #36

8) MIDI Exclusive Page 2 Distortion

Highpass	Contr #35
Output	Contr #36
Drive	Contr #37
Harmonic	Contr #38
Direct	Contr #39
Points 1 - 16	Contr #01 - Contr #16

9) MIDI Exclusive Page 2 Filter

Volume	Contr #00
Parameters 1 - 31	Contr #01 - Contr #31

10) MIDI Exclusive Page 2 Pitch Transposer

Semitones	Contr #01
Cent	Contr #02
Loop Parameter	Contr #03
Output Level	Contr #05

SECTION K

1) Saving a Backup of the Sound Recording Directory

We recommend saving a backup of the Directory on the Hard Disk.
If for instance you delete an EVENT or a Multitrack and you want to get it
back you can reload the backup of the Directory.

Go to Page 0.

Move the cursor to **LOAD OLD WORLD** and use the key



to roll to **SAVE DIRECTORY**

Press



Are you sure ?



Loading the backup of the Directory:

Go to the same field and roll to **LOAD DIRECTORY**

Press



Are you sure ?



Page 0.02 DIAGNOSTIC

1) General survey

This Page features all nessecary hard-disk initilisation functions and the formatting routines for the main drive as well as for the expander drive.

Note:

The hard disk formatting utility is a routine that should not be used by the user. Under normal conditions there should be no reason to reformat the harddisk. This function should only be executed in the service field.

Besides the harddisk functions you will find the tapestreamer utilities, which are used for saving the harddisk data on an external medium. These functions only work if the Tape-Streamer option is installed in your HDU.

Call up Page 0.02

You will see the following display:

Tapestreamer				***Harddisk***		SR
Load	Save	Exit	Veri	Init	Format	HD: 0
Date:	19	.	02	.	1987	ES
N:	[REDACTED]					
002	DIAGNOSTIC					EX

2) Initializing the Hard Disk Sound Recording Directory

This function erases **all** your Multitracks, EVENTS and Songs, so that the Recording Directory is completely empty and ready for new recordings.

All your Arrangements, effect programs and softkey-recordings will be kept and not deleted (they are saved under **World**).

We recommend using this feature when you start a new production and your data is saved onto tape. (optional Tape Streamer)

Move the cursor to the **Init** field and press **EX**. The display shows:

Delete Directory?	1
Are you sure ?	1

3) tape streamer operation

This hardware option is described in software Version 1.5.

This page is reserved for the tape streamer option.

4) Identity Number of your Software

Each HDU has its own ID Number.

You find this number if you (on Page 0) roll the field **LOAD OLD WORLD** until you read **GET SYS INFO**.

Press EX and this info appears:

ID. No. : 119292	SR
Track Map :	
512	ES
HDU Software Version 1, Revision 0	
000 Enter Page #	GET SYS INFO EX

4) The Softkey Recorder

The Softkey Recorder allows you to record chains of inserts which you do on the keypad of the COMMANDER.

You can record 100 different chains each with up to 50 inserts.



Let's do it with an example:

Go to Page 2 and press  twice to go into recording mode

Now the symbol SR disappears and you have to insert a two digit number (use 00).

Right after inserting the number the recording symbol appears 

Now you are in recording condition . Please insert one by one:

 then 0, 4, 7 then  then 

then  then   then 

Now the COMMANDER displays : 

on the Flanger Page.

Press  this means you are terminating the softkey-recording.

Now press "1" for start and when the playback is running, ES for stop.

Go to any Page and call your Softkey Recording with:  and 00

You can call SR on any Pages no matter where it was recorded it will start on the right Page.

Note:

The Softkey Recordings must be saved together with your Arrangements and Programs on Page 0 under **SAVE NEW WORLD** before you switch off the HDU.